

Site Preparation Guide

UHP Motion Control System

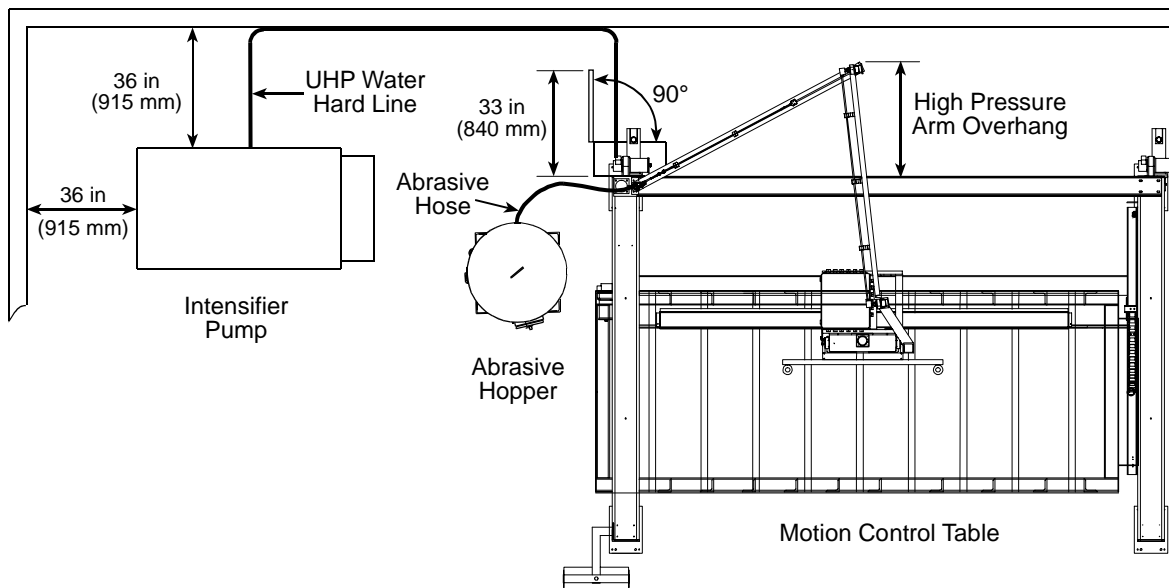

**Publication
information**

Revision A March 2006

Copyright information

©2006 Jet Edge, a division of TC/American Monorail, Inc. All rights reserved.

All information within this document is proprietary to Jet Edge. You may not copy or reproduce its contents without permission, except where specifically noted.

**Trademark
information**

Jet Edge is a registered trademark of TC/American Monorail, Inc.

Jet Edge and OmnJet are registered trademarks of TC/American Monorail, Inc.

Jet Edge, OmnJet, and Permalign are registered trademarks of TC/American Monorail, Inc.

Contacting Jet Edge

Jet Edge
12070 43rd Street Northeast
Saint Michael, Minnesota 55376-8427 USA

Address your technical support questions to the Service department.

Phone: 1-763-497-8700
Fax: 1-763-497-8701 (sales)
1-763-497-8702 (service)
Toll Free: 1-800-538-3343 (1-800-JET EDGE)

Web Site: <http://www.jetedge.com>
Email: sales@jetedge.com
service1@jetedge.com



Site Preparation Guide

This document provides information about preparing your facility for the installation of a Jet Edge motion control system. The facility must have adequate air, water, sewer drain, and electrical service as described in this document prior to the installation of Jet Edge equipment.

Contents	Physical Requirements	4
	Electrical Requirements	6
	Pneumatic Requirements	7
	Water Requirements	8
	Water Impurities	9
	Equipment Dimensions	13
	Intensifier Pump Dimensions	13
	High Rail Dimensions	14
	Dense Phase Hopper Dimensions	16
	Specifications	17
	Hardware Considerations	19
	Intensifier Pump Considerations	19
	High Rail Considerations	20
	Dense Phase Hopper Considerations	21
	Installation	22
	Customer's Responsibilities	23
	Required Equipment	24
	Required Service Tools	25
	Hydraulic Fluid Selection Chart	26
	Training	28

Physical Requirements

The work site must accommodate the dimensions and weight of the system components. Floor material must be of concrete capable of supporting the weight of the machine, and thick enough to provide resistance to vibration.

Environmental

Relative humidity must be non condensing: maximum of 95% humidity at 95°F (35°C), otherwise additional heat exchanging may be required for hydraulic fluid cooling.

- For the standard open loop cooling (cooling water flows to drain), the ambient temperature must be within 50°–95° F (10°–35° C).
- Optional closed loop chillers provide supplemental cooling (cooling water chilled and recirculated), if the ambient temperature ranges between 95°–110° F (35°–43° C) the chiller capacity is reduced 1% per 1° F; ranges between 110°–120° F (43°–49° C) the capacity is reduced 2% per 1° F.

Certain locations may be hazardous if the atmosphere contains gas, vapors, or dust in explosive concentrations. Refer to the National Electric Code (NEC), OSHA requirements, and local codes for detailed information about environmental criteria.

Noise

The high rail motion control system produces noise when the UHP water travels through air to the cutting surface. There are cutting techniques and options to reduce the amount of noise generated by a waterjet.

- A waterjet can produce 80–110 db depending on options and cutting techniques.
- The intensifier pump generates approximately 80–85 db.

Hearing protection is required for operators and others who spend time in the room with the motion control system.

The following affect the amount of noise produced by a waterjet:

- When the water level is below the cutting surface, noise is increased.
- When the water level is at the cutting surface, noise is reduced.
- When the water level is above the cutting surface and the waterjet tip is submerged, noise is greatly reduced.
- A water curtain surrounding the waterjet nozzle reduces noise.

Cooling Guidelines

The heat exchanger uses regular tap water for cooling hydraulic fluid. A consistent water flow of 3–12 gpm (19 lpm) is required, at an inlet temperature not exceeding 70° F/21° C. Water flow depends on the pump model, larger pumps require more water. The water temperature also affects the flow, warmer water requires more water to cool the pump.

Public utility water is usually acceptable for cooling purposes. In situations where the water contains heavy mineral deposits, the exchanger tubes may eventually become restricted by particle buildup which reduces the cooling efficiency. If this is a chronic problem filtration and/or softening may be needed.

Depending on plant setup, ambient temperature can also be a factor in cooling. Where the equipment is confined to a small high-temperature space, additional cooling may be required. Recycling-type supplemental cooling units can also be installed where the volume of fresh water used is a consideration.

Heat load The intensifier pump generates heat. Depending on the heat load from other equipment in the work area you might need to consider cooling the work area. See “[Heat Load \(BTU/hour\)](#)” on page 17.

Ultra high pressure tubing The ultra high pressure (UHP) tubing must be anchored to a stable structure to prevent flexing which can crack the UHP tubing. The UHP tubing should be secured to prevent the tubing from sagging.

The UHP tubing is routed from the intensifier pump, down to the floor, and to the nearest wall. The tubing is routed along the wall towards the motion control table, across the floor and up the leg supporting the high pressure arm assembly. Tubing can be routed overhead but must be supported.

Equipment locations The dimensions of the work site and the Jet Edge equipment often dictates where equipment can be located. See “[Equipment Dimensions](#)” on page 13 for specific dimensions and “[Hardware Considerations](#)” on page 19 for more information.

- All connections to the motion control table are at the left rear leg.
- The abrasive hopper should be as close as possible to the leg where the high pressure arm is mounted to keep the length of abrasive hose to a minimum.
- Equipment should be placed at least 36 inches (915 mm) from any walls or structures to allow access to the equipment for maintenance or service.
- The high pressure arm overhang of the high rail must be considered for the placement of the motion control table.
- Access to the electrical assembly must be clear and the door must be able to open 90° of the door swing. The door requires 33 inches (840 mm) to open.

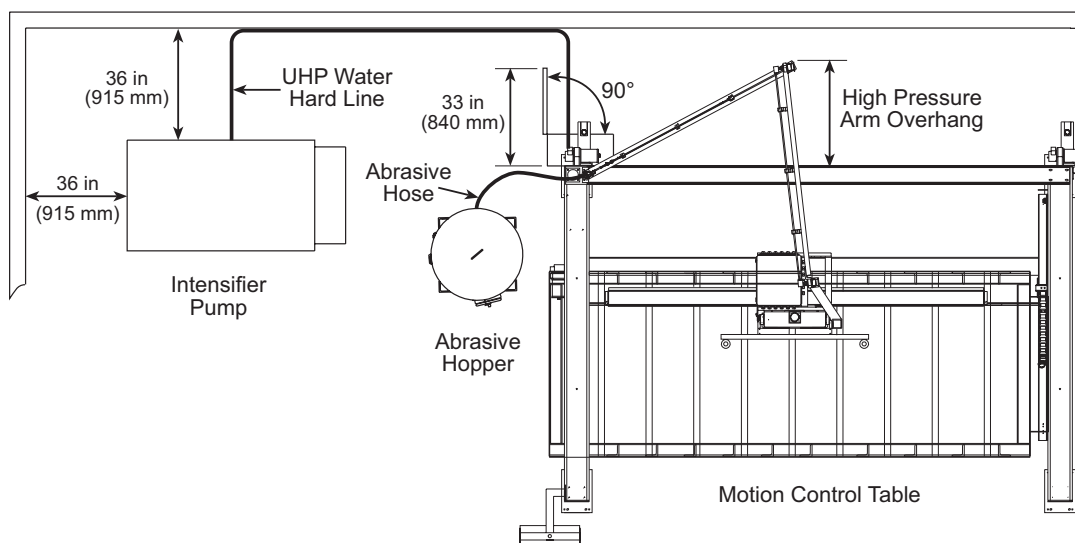

Typical Equipment Locations

Electrical Requirements

For complete information about electrical service requirements refer to local building codes, NEC and OSHA provisions. Electrical requirements may vary depending on the motor type chosen.

Note *Local electrical code and regulations must be followed. If local codes conflict with Jet Edge requirements contact Jet Edge for additional information.*

When connecting the source power be aware that the full load amperage (FLA) listed on the intensifier pump motor does not reflect the total requirement for the entire setup. Any accessories running off the same power source increase the minimum necessary supply amperage.

- Each machine should be on a dedicated, fused circuit.
- The intensifier pump and high rail should have a dedicated electrical box with a disconnect.
- The intensifier pump and the high rail motion control table are ordered with a voltage/frequency option to accommodate the local electrical power.
- Electrical connections to the motion control table are wired to an electrical box located below the electrical assembly on the left rear leg of the table.
- Electrical connections to the intensifier pump are wired at the rear of the electrical assembly on the right side of the pump.
- The basic models of the abrasive hoppers have an electrical cord that plugs into a 115 V(ac) 60 Hz single phase wall outlet.

Pneumatic Requirements

A compressed air supply is needed to pneumatic devices. Air operates the following components:

- Each OmniJet waterjet uses air to turn the UHP water on and off.
- The Dense Phase Hopper uses air to pressurize the abrasive holding tank and the abrasive feed hose to the mini hopper.
- The mini hopper uses air to operate a slide gate that turns the abrasive flow on and off.
- The catch tank bladder option uses air to fill an air bladder that changes the water level in the catch tank.

Shop air

The site requires an air compressor that is capable of providing an adequate volume of air to operate the various components in your system.

- 80–90 psi (5.6–6.2 bar)
- Refer to “[Specifications](#)” on page 17 for specific equipment air flow requirements:
- Filtered dry air is required; moisture issues require an air dryer.

Air distribution

Air is usually distributed with hard lines that are anchored along the building walls or roof structure. Trunk lines are located near the equipment that requires an air supply. Trunk lines are terminated with a standard, female, pneumatic quick-disconnect fixture.

Air hoses with mating quick-disconnect fixtures connect the equipment to the air distribution system. The connections at Jet Edge equipment have male quick-disconnect fixtures.

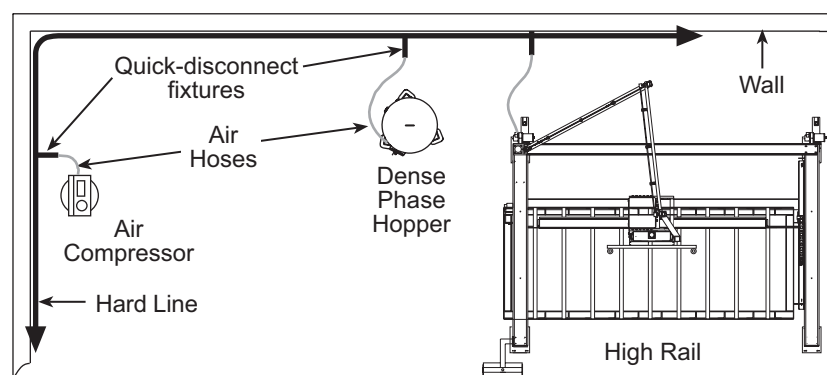

Filtration

Filter/regulators are located on the Dense Phase Hopper abrasive supply and the High Rail motion control system. The air supply connection is made at the filter/regulator.

Water Requirements

Two water sources are required for the intensifier pump:

- The water source to supply the intensifier pump that produces the ultra high pressure (UHP) water *must* be pretreated for either the removal of hardness, reduction in total dissolved solids, or regulation of the pH level.
- The water source to supply the heat exchanger *should* be treated to remove any impurities that might react with the copper in the heat exchanger. The temperature of the cooling water is an important factor to keep the hydraulic fluid at the proper operating temperature.

The water supplied to the intensifier is a crucial factor in waterjet cutting because of its direct influence on the service life of equipment components such as check valves, seals, and the orifices that shape the water stream. A high concentration of Total Dissolved Solids (TDS) causes accelerated wear of these components.

As part of pre installation planning, have a water quality analysis performed by a commercial company that specializes in water conditioning equipment. Water quality available for the installation is unique for each application and geographic location. Consult a water purification supplier to determine the most suitable equipment for specific local conditions. The minimum information that should be furnished is:

- TDS
- Silica content
- pH value

Inlet water should be pretreated for either the removal of hardness or reduction in total dissolved solids. Water softening is an ion exchange process that removes scale forming minerals such as calcium. TDS reduction can be accomplished with either deionizing (DI) or reverse osmosis (RO) equipment. DI or RO will usually provide better component life than water softening processes.

The best pretreatment process for a specific application is based on the original water quality and the desired service life of affected components. Water treatment resulting in TDS content of less than 0.5 ppm is not recommended.

Cooling water

The heat exchanger uses regular tap water to cool the hydraulic fluid. The hydraulic fluid temperature must be maintained below 120° F (49° C). A constant water flow of 3–12 gpm (11–45 lpm), depending on the pump model, is required at an inlet temperature not to exceed 70° F (21° C). Public water is usually acceptable for cooling purposes. The ambient temperature can also be a factor in cooling. Additional cooling might be required if the pump is confined in a small, high temperature space.

Sewer Requirements

Two independent lines to the sewer drain are required. Leakage water and coolant water exiting must be separate, or the collector manifold may overflow. The drain should be as close to the machine as possible. Venting of water from the exit ports is gravity-induced and must have a sufficient vertical drop to prevent backup.

Water treatment guidelines

- Low TDS (less than 100 ppm): Considered good water quality and can be treated by softening.
- Moderate TDS (100 to 200 ppm): Can be treated either with softening or TDS reduction (RO or DI).
- High TDS (greater than 200 ppm): Considered poor water quality and should be treated with RO or DI.
- High silica content (greater than 15 ppm): Can only be removed with RO (reverse osmosis) or DI (deionizing) systems.
- Carbon filtration can remove objectionable odors. This is often a consideration in food processing applications.
- The treated water must have a pH value of 6.5 to 8.5, and should be filtered to 0.5 microns absolute to remove suspended particulates such as dirt, silt, and algae.

The physical process of pressurizing the water within the intensifier cylinder causes a rapid rise in water temperature. The temperature of the water supplied to the intensifier assemblies should be kept as low as possible (70° F/21° C maximum).

Excessive inlet water temperatures can cause accelerated wear and reduce component service life, especially the high pressure seals. In installations where initial supply water temperature is above the maximum recommended, additional pre-cooling may be required.

Water Impurities

Scale forming constituents, besides the material build-up, they cause erosion; dissolved solids come out of solution and act as abrasive. Primary components affected are: orifices, high pressure seals.

Waterjet components are subject to stress levels which are sensitive to the effect of compounds in water that can lead to localized damage, like corrosion; which can lead to crack initiation failure of metallic pressurized components.

Hardness, Iron, and manganese

The three components can form deposits, and/or cause erosion; specially at the nozzle affecting cutting efficiency and unscheduled downtime. High pressure seals are also affected.

Considering the other elements are within acceptable levels, in most cases a water softener will satisfy both, flow rate and capacity requirements.

Observe the usual hardness, iron and manganese application criteria. Use appropriate accessories when the hardness to iron ratio is less than 8: 1. When iron or manganese is the only problem, use properly sized filtering elements with surface active agents for retention.

**Dissolved solids,
chloride, silica**

High TDS and chloride can promote corrosion on wetted metal parts, and TDS and silica can contribute to scaling and erosion. When raw water TDS exceeds 200 mg/l, or chloride exceeds 100 mg/l, or silica exceeds 15 mg/l, RO (reverse osmosis) or DI (deionizing) water treatment is recommended. At or below "Maximum Allowable" amounts, TDS can not be reduced by softening.

Common Impurities Found In Water

Constituent	Chemical Formula	Notes
Calcium	Ca	When dissolved make the water hard. Contributes to the formation of Scale.
Chloride	Cl	Adds to solid content and increases corrosive character of water; in relative percentage presence with oxygen induces stress corrosion cracking
Iron	Fe ⁺⁺ (ferrous) Fe ⁺⁺⁺ (ferric)	Discolors water or precipitation. Source of scale and erosion.
Manganese	Mn ⁺⁺	Same as Iron
Magnesium	Mg	When dissolved makes the water hard. Contributes to the formation of scale.
Nitrate	NO ₃	Adds to solid content, but its effect is not usually significant industrially.
PH		Varies according acidic or alkaline solids in water.
Silica	SiO ₂	Causes scale.
Sodium	Na	Found naturally; and introduced to water in the ion exchange water softening process.
Sulfate	SO ₄	Adds to solid content of water; combines with calcium to form calcium sulfate scale.

Water Analysis

A water analysis report usually data for a variety of impurities, the impurities listed in the following table are the most significant for ultra high pressure (UHP) equipment.

Water Quality Impurity Limits

Impurity	Acceptable Range*
Calcium	N/D to 25 mg/L
Chloride (Cl)	N/D to 15 mg/L
Iron (Fe)	N/D to 0.2 mg/L
Manganese (Mn)	N/D to 0.5 mg/L
Magnesium (Mg)	N/D to 0.1 mg/L
Nitrate (N)	N/D to 25 mg/L
pH	6.5–8.5
Silica (SiO₂)	N/D to 14 mg/L
Sodium (Na)	N/D to 50 mg/L
Sulfate (SO₄)	N/D to 25 mg/L
TDS	5–200 mg/L
Total hardness (CaCO₃)	1–25 mg/L
Turbidity	1–5 NTU

* Non Detectable

Terminology

Anions—ions (atoms or molecules with an electrical charge) with a negative (-) electrical charge, so named because they go toward the anode in an electric field. The main anions in water are hydroxide (OH⁻), carbonate (CO₃⁻²), bicarbonate (HCO₃⁻) (which together comprise "alkalinity"), sulfate (SO₄⁻²), nitrate (NO₃), and chloride (Cl⁻)

Cations—ions (atoms or molecules with an electrical charge) with a positive (+) electrical charge, so named because they go toward the cathode in an electric field. Besides the hardness ions, the main cations in water are sodium, Na⁺, and potassium, K⁺.

Chloride, Cl—a common mineral component, can be found in elevated levels near seawater and other salt supplies, which can cause taste problems and can contribute to corrosion resulting in stress corrosion cracking. Recommended U.S. limit is 0.3 mg/L.

Iron, Fe—causes rust stains and premature failure of high pressure components. The recommended U.S. limit is 0.3 mg/L.

Manganese, Mn—causes scale when dissolved. Often occurs in combination with iron. The recommended U.S. limit is 0.05 mg/L Mn or a total of 0.3 mg/L of Fe + Mn.

Nitrate/Nitrite, NO₃/NO₂—important because of toxicity to infants, nitrate comes from fertilizers and animal wastes. Water supplies with high nitrate levels should also be screened for agricultural pesticides and bacterial contamination. The mandatory limit under U.S. regulations is 10 mg/L This is usually not a concern in high pressure equipment.

pH—the acid strength of water on a scale of 0 to 14 (neutral = pH 7.0). Values from 0 to 7 are increasingly more acidic; values from 7 to 14 are increasingly more alkaline. The recommended range for drinking water under the U.S. regulations is 6.5 to 8.5. If the pH level is too low, component life can be affected.

Silica, SiO₂—a naturally occurring dissolved mineral, which produces a glassy scale.

Sulfate, SO₄⁻²—a common mineral component, only rarely grousing at excessive levels, which can cause calcium sulfate scale when combined with calcium. Recommended U.S. limit is 250 mg/L.

Total Hardness—the sum of all metal ions, mostly Calcium and Magnesium. When heated or evaporated, hard water can cause lime scale that can deposit on components which results in loss in efficiency.

Turbidity—cloudiness in water caused by the dispersion of light by extremely tiny particles. Measured on an arbitrary scale of Nephelometric Turbidity Units (NTUs). The mandatory maximum under U.S. regulations is 0.5 NTU.

Equipment Dimensions

Intensifier Pump Dimensions

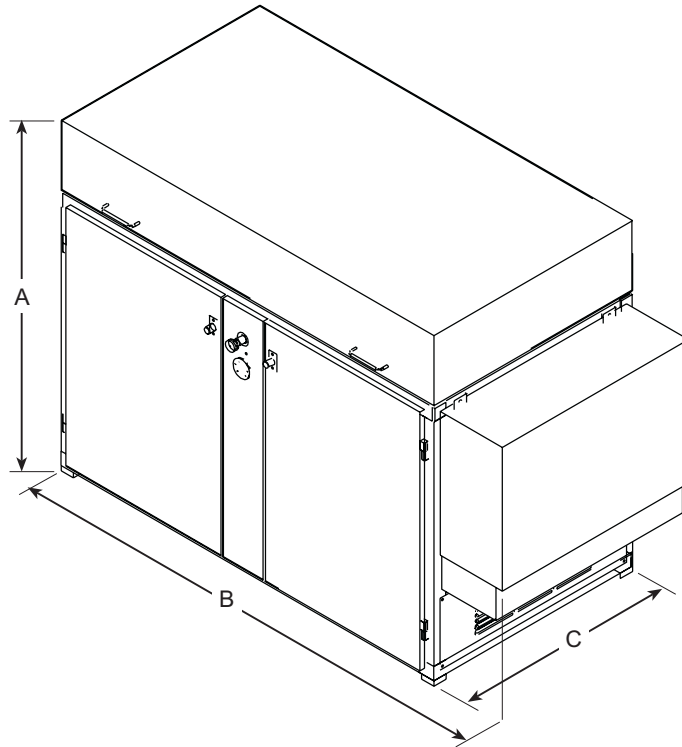

Intensifier Pump Dimensions

Model	Height (A)	Width (B)	Depth (C)
36-50	52 in (1321 mm)	80 in (2032 mm)	37 in (940 mm)
36-100	60 in (1524 mm)	96 in (2438 mm)	37 in (940 mm)
36-200	61 in (1549 mm)	92 in (2337 mm)	57 in (1448 mm)
55-30	53 in (1346 mm)	64 in (1626 mm)	30 in (762 mm)
55-50	53 in (1346 mm)	71 in (1803 mm)	36 in (914 mm)
55-50C	53 in (1346 mm)	74 in (1880 mm)	34 in (864 mm)
55-50R	55 in (1397 mm)	54 in (1372 mm)	54 in (1372 mm)
55-75	55 in (1397 mm)	86 in (2184 mm)	40 in (1116 mm)
55-100	55 in (1397 mm)	86 in (2184 mm)	40 in (1116 mm)
55-150	55 in (1397 mm)	86 in (2184 mm)	52 in (1321 mm)
55-200	61 in (1549 mm)	92 in (2337 mm)	57 in (1448 mm)

High Rail Dimensions

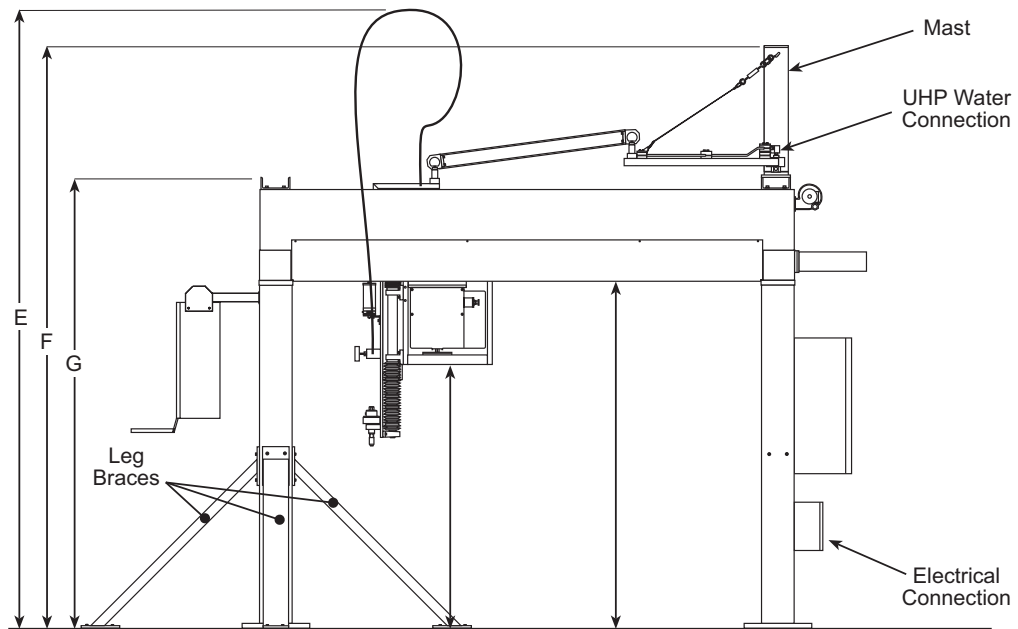
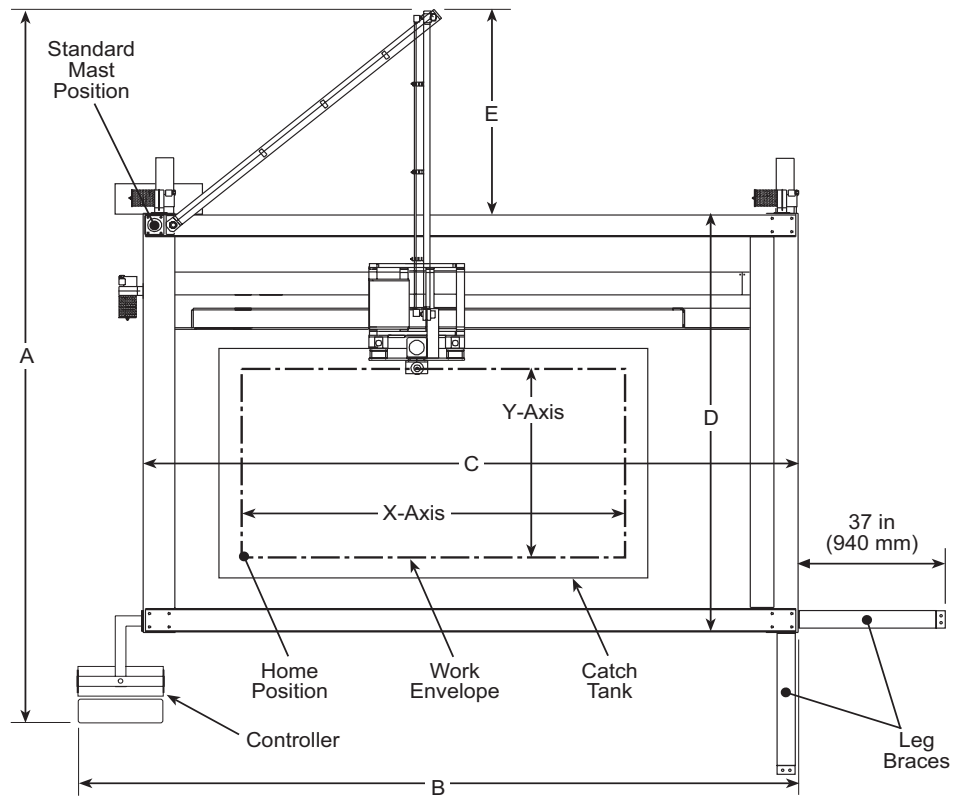

High Rail Dimensions in inches (millimeters)

Model	A	B	C	D	E	Work Envelope (Y-axis x X-axis)*
44	169 (4293)	136 (3455)	117 (2975)	110 (2795)	28 (711)	48 x 48 (1219 x 1219)
46	183 (4648)	160 (4065)	141 (3585)	110 (2795)	42 (1067)	48 x 72 (1219 x 1828)
48	190 (4826)	184 (4675)	165 (4195)	110 (2795)	49 (1245)	48 x 96 (1219 x 2438)
410	201 (5105)	208 (5285)	189 (4805)	110 (2795)	60 (1574)	48 x 120 (1219 x 3048)
412	207 (5258)	231 (5870)	213 (5310)	110 (2795)	66 (1676)	48 x 144 (1219 x 3657)
68	221 (5613)	184 (4675)	165 (4191)	143 (3635)	47 (1194)	72 x 96 (1828 x 2438)
610	231 (5867)	207 (5260)	188 (4775)	143 (3635)	57 (1448)	72 x 120 (1828 x 3048)
612	231 (5867)	232 (5895)	213 (5410)	143 (3635)	57 (1448)	72 x 144 (1828 x 3657)
614	255 (6477)	255 (6480)	236 (5995)	143 (3635)	81 (2057)	72 x 168 (1828 x 4267)
84	255 (6477)	136 (3460)	117 (2975)	164 (4170)	48 (1219)	96 x 48 (2438 x 1219)
812	280 (7112)	232 (5895)	213 (5410)	164 (4170)	73 (1854)	96 x 144 (2438 x 3657)
814	292 (7417)	256 (6505)	237 (6020)	164 (4170)	85 (2159)	96 x 168 (2438 x 4267)
106	289 (7341)	160 (4065)	141 (3585)	188 (4775)	59 (1499)	120 x 72 (3048 x 1828)
108	313 (7950)	184 (4675)	165 (4195)	199 (5055)	59 (1499)	120 x 96 (3048 x 2438)
1012	313 (7950)	232 (5895)	213 (5410)	199 (5055)	83 (2108)	120 x 144 (3048 x 3657)
1014	326 (8280)	256 (6505)	237 (6020)	199 (5055)	96 (2438)	120 x 168 (3048 x 4267)
126	337 (8560)	160 (4065)	141 (3585)	212 (5385)	83 (2108)	144 x 72 (3657 x 1828)
128	337 (8560)	184 (4675)	165 (4195)	212 (5385)	83 (2108)	144 x 96 (3657 x 2438)
1210	337 (8560)	208 (5285)	189 (4805)	212 (5385)	83 (2108)	144 x 120 (3657 x 3048)
1212	350 (8890)	232 (5893)	213 (5410)	212 (5385)	96 (2438)	144 x 144 (3657 x 3657)
1214	354 (8992)	256 (6502)	237 (6020)	212 (5385)	100 (2540)	144 x 168 (3657 x 4267)
146	346 (8788)	160 (4064)	141 (3585)	236 (5995)	68 (1727)	168 x 72 (4267 x 1828)
148	†	184 (4675)	165 (4195)	236 (5995)	†	168 x 96 (4267 x 2438)
1414	†	256 (6505)	237 (6020)	236 (5995)	†	168 x 168 (4267 x 4267)

* Catch tank is 12 inches (305 mm) larger than work envelope plus the length of a spreader bar (if used).

† High pressure arms not assigned (retracted distance can not be determined).

Height dimensions The height dimensions are the same for all models:

E—height to top of UHP whips = 137 in (3480 mm)

F—height to top of mast = 123 in (3130 mm)

G—height to top of support beam = 95 in (2390 mm)

Dense Phase Hopper Dimensions

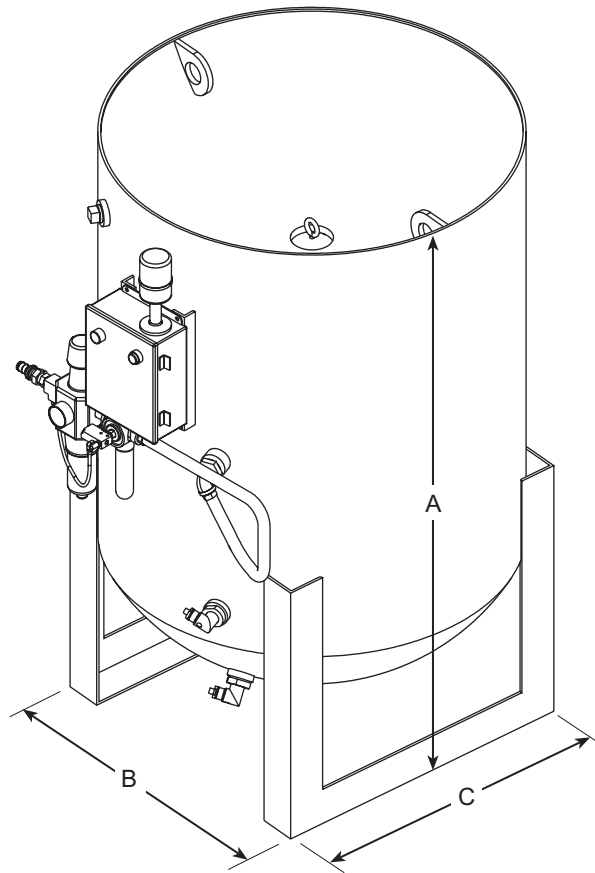

Dense Phase Hopper Dimensions and Weight

Model*	A	B	C
3.5	42 in (1070 mm)	24 in (610 mm)	24 in (610 mm)
6.5	48 in (1220 mm)	30 in (765 mm)	34 in (865 mm)
20	60 in (1525 mm)	36 in (915 mm)	46 in (1170 mm)
35	85 in (2160 mm)	38 in (965 mm)	46 in (1170 mm)

* The model number is the capacity of the hopper in cubic feet.

Specifications

Intensifier Pump General Specifications

Parameter	Specification
Low pressure water	See “Water Requirements” on page 8.
Input pressure	Minimum pressure 40 psi (3 bar)
Input temperature	Maximum temperature 70°F (21°C)
Filtration	On-board filtration to 0.45 micron
High pressure water	See Water Output Flow Rate in the Intensifier Pump Model Specific Specifications table
Cooling water	See “Water Requirements” on page 8.
Input pressure	Minimum pressure 40 psi (3 bar)
Input temperature	Maximum temperature 70°F (21°C)
Hydraulic fluid	See the “Hydraulic Fluid Selection Chart” on page 26.
Fluid capacity	See Hydraulic Fluid Capacity in the Intensifier Pump Model Specific Specifications table.
Filtration	10 micron full flow
Fluid type	Standard: Medium grade turbine ISO USDA food grade: #4010 Quinplex or equivalent

Intensifier Pump Model Specific Specifications

Model	Electric Motor Power	Heat Load (BTU/hour)	Hydraulic Fluid Capacity	Water Output Flow Rate	Weight*
36-50	50 hp (37 kw)	37,305 BTU	45 gal (170 L)	1.9 gpm (7.2 Lpm)	3020 lb (1370 kg)
36-100	100 hp (75 kw)	80,422 BTU	45 gal (170 L)	4.0 gpm (15.1 Lpm)	4600 lb (2087 kg)
36-200	200 hp (149 kw)	124,920 BTU	95 gal (360 L)	6.1 gpm (23.1 Lpm)	6200 lb (2812 kg)
55-30	30 hp (22 kw)	21,298 BTU	20 gal (76 L)	0.65 gpm (2.5 Lpm)	2000 lb (907 kg)
55-50	50 hp (37 kw)	25,290 BTU	†	1.0 gpm (3.8 Lpm)	2500 lb (1134 kg)
55-50R	50 hp (37 kw)	39,000 BTU	45 gal (170 L)	1.0 gpm (3.8 Lpm)	3650 lb (1656 kg)
55-75	75 hp (56 kw)	55,057 BTU	60 gal (227 L)	1.5 gpm (5.7 Lpm)	4100 lb (1968 kg)
55-100	100 hp (75 kw)	96,625 BTU	60 gal (227 L)	2.0 gpm (7.6 Lpm)	4600 lb (2087 kg)
55-150	150 hp (112 kw)	124,920 BTU	75 gal (284 L)	2.9 gpm (10.9 Lpm)	6100 lb (2767 kg)
55-200	200 hp (149 kw)	124,920 BTU	75 gal (284 L)	4.0 gpm (15.2 Lpm)	6200 lb (2812 kg)

* Dry weight; units shipped by air have no hydraulic fluid; units shipped by ground have hydraulic fluid in the tank.

† 55-50A 26 gal (98 L); 55-50B 22 gal (83 L); 55-50C 32 gal (122 L)

High Rail Specifications

Parameter	Specification
UHP Water Connection	3/8 inch Autoclave-style high pressure coupling
Air supply	Filtered and dry air supply
Input	80–90 psi (5.5–6.2 bar)
Flow	6 cfm (0.17 m ³ /m) minimum
Catch tank drain	1 in (25 mm) hose connection
Electrical power	Specific to local requirements

Dense Phase Hopper Specifications

Parameter	Specification
Air supply	Filtered and dry air supply
Input	80–90 psi (5.5–6.2 bar)
Flow	11 cfm (0.31 m ³ /m) minimum
Abrasive	
Delivery rate	
main hopper*	0.25–30 lb/m (0.11–13.6 kg/m)
mini hopper	0.25–1.8 lb/m (0.11–0.8 kg/m) nominal 3.5 lb/m (1.6 kg/m) maximum†
Media size	30–200 mesh
Capacity and weight (approximate)	3.5 Cubic Foot 400 lb (180 kg) 6.5 Cubic Foot 800 lb (360 kg) 20 Cubic Foot 2500 lb (1130 kg) 35 Cubic Foot 4000 lb (1900 kg)
Electrical power	
Basic controls	115 V(ac)
Advanced controls	24 V(dc)
Weight	approximate, empty
3.5 Cubic Foot	235 lb (110 kg)
6.5 Cubic Foot	340 lb (155 kg)
20 Cubic Foot	785 lb (360 kg)
35 Cubic Foot	1020 lb (465 kg)

* Main hopper can supply up to four mini hoppers.

† Requires high flow equipment.

Hardware Considerations

Review the following installation information for each machine.

Intensifier Pump Considerations

The intensifier pump supplies the ultra high (UHP) pressure water to the high rail table. Several water connections are required for the intensifier pump.

Water Connections

Connection	Type
Leakage Water Out	1/2 inch NPT
High Pressure Water Out*	3/8 inch high pressure coupling
Coolant Water Out†	1/2 inch NPT
Coolant Water In‡	1/2 inch NPT
Filtered Water In‡	1/2 inch NPT

* Model 55-200 has a 9/16 inch high pressure coupling.

† Models 36-200, 55-150, and 55-200 have a 3/4 inch NPT connection.

‡ Models 36-200, and 55-200 have a 3/4 inch NPT connection.

- The intensifier pump can be located anywhere in the plant. The intensifier pump comes with 25 feet (7500 mm) of ultra high tubing. The way the tubing should be routed will require the intensifier pump to be within about 10 feet (mm) of the motion control table. For any other location additional (optional) UHP tubing is required.
- The UHP stainless steel tubing must be rated for 60,000 psi (4125 bar).
- Cover the tubing with flexible sheathing to protect personnel in case of a line break. A gauge (60–80 ksi capacity) is required in the UHP line from the machine to the cutting equipment to monitor output water pressure.
- Clamp the UHP tubing to a nearby wall or overhead bracing for stability. Vibration caused by water pulsations can induce failure, especially at connection points, unless the tubing is securely supported.
- UHP autoclave style connections are required at the intensifier pump output and the high rail table input.
- All tap water supply ports are U.S. standard NPT thread.
- Water supply and drain lines should be Parker 801-8 or equivalent, PVC, or stainless steel. Do not use copper, galvanized, or iron pipe.

High Rail Considerations



Do not position the rear of the high rail table too close to any structures. The high pressure arm on top of the high rail will articulate out and over the rear of the machine. If the arm movement is restricted, the arm will become damaged.

Ensure the high pressure arm can operate through the entire work envelope without interference at the rear of the machine.

Controller location

The controller is located on the left front leg of the high rail. This is the location where the operator runs the machine; it is near the home position of the motion control system. For custom applications the controller can be located to another location (such as the right front leg or a stand alone console).

Leg braces

Leg braces provide support for the high rail legs. Four or more legs are used; the number of braces is system specific and factor in the size of the foot print, tool movement speed, and the mass of the Z-package. The leg braces can be placed on any side of a leg. Leg braces add 37 inches (940 mm) to the high rail foot print when they are attached to the inboard or outboard side of the legs.

Note *When determining the foot print of the high rail table remember to account for any leg extensions that might be included.*

Catch tank

The catch tank is 12 inches (305 mm) larger than the high rail work envelope. The x-axis of the work envelope can be increased with the use of a spreader bar. If a spreader bar exceeds four feet (1220 mm) the catch tank might affect the footprint dimension.

Mast location

The mast that supports the high pressure arms is located on the left rear leg. For custom installations it can be mounted on other legs. The location of the mast determines which side of the high rail the high pressure arms extend when they are retracted.

The mast location affects where the UHP water, abrasive feed line, and pneumatic connections are located.

Water connections

The high rail motion control system requires an ultra high pressure (UHP) water connection from an intensifier pump. The connection is made to the swivel located at the top of the leg with the mast. The UHP plumbing is typically routed from the floor up the leg. The UHP can be routed from other locations with proper support for the UHP water line.

The catch tank has a one inch (25 mm) water overflow hose that must be routed to a drain.

Electrical connection

Incoming electrical power is connected at the junction box located on the left rear leg of the machine, below the electrical assembly. For custom applications the electrical assembly can be mounted to another leg of the motion control system. The door of the electrical assembly must be able to fully open

Dense Phase Hopper Considerations

The Dense Phase Hopper supplies abrasive to the mini hopper(s) which in turn regulates the abrasive supply to the Permalign abrasivejet. The mini hopper is mounted on the Z-axis assembly of the high rail motion control table.

- The abrasive hose run from the dense phase hopper to the high rail table should be as short as possible.
- The abrasive hose is routed from the left rear leg of the high rail, along the high pressure arm assembly to the mini hopper on the Z-axis.

The Dense Phase Hopper should be located as close to the leg of the high rail where the mast is installed as possible. Access to the hopper for abrasive refills should also be considered.

Installation

Jet Edge will provide a qualified service engineer to assist with the installation, start-up, and training of the system following the customer's completion of the pre-installation requirements as outlined by Jet Edge.

Installation Start-up & Training

Jet Edge's installation/start-up services include the following:

- Jet Edge will provide a qualified service engineer for up to four consecutive working days during the normal working days of Monday through Friday. Working days are eight hours each during normal business hours unless other arrangements have been agreed upon with Jet Edge. Jet Edge may at its option include the services of an additional service engineer to assist with the installation/start-up for part of the service period.
- The Jet Edge service engineer will review the customer's installation responsibilities to ensure they have been completed in accordance with Jet Edge's recommendations. The Jet Edge service engineer will assemble, level, and align the motion control system with the assistance of the customer. The Jet Edge service engineer will custom form all high pressure tubing from the intensifier pump to the motion control system with the assistance of the customer who is to provide and mount any support bracketing that may be required. The Jet Edge service engineer will perform initial start-up of the system.

Note *If an Abrasive Recycling system is purchased, it is the customers responsibility to have enough abrasive (new or used) to fill the cutting tank to a minimum depth of 12" to start-up the recycling system and make the necessary adjustments. Failure to have the necessary abrasive to test the unit will result in only an overview of the unit. If the customer requires a return trip to start-up the abrasive recycling system, it will be billed at our standard rate and will not affect the final payment due date.*

Customer's Responsibilities

The customer's installation responsibilities include the following:

- Uncrating and placement of all equipment with the exception of the motion control system and cutting tank.
- The ultra-high pressure pump must be located within ten feet of the motion control system unless special provisions have been made for remote locations.
- The area in which the motion control system will be installed must be left open. The leg orientation is to be chalked out on the floor by the Jet Edge service engineer.
- The customer will uncrate and provide the means for positioning the motion control system and catch tank in its final location with the supervision of a Jet Edge service engineer.
- The customer will supply any special equipment and/or tooling that may be necessary for installation/start-up of the system. See “[Required Equipment](#)” on page 24.
- The customer will perform all electrical, low-pressure water, cooling, drain, and air connections, including interconnects between system components with the supplied Jet Edge documentation listing all connection points to all codes that apply to customer's site.
- The customer will supply and mount any necessary bracketing that may be needed to support the high pressure tubing.
- The customer should schedule Jet Edge's installation/start-up services to coincide with the completion of the customer's responsibilities at least three weeks prior to the desired date by calling the Jet Edge project coordinator.
- The customer must supply at least one qualified technician to assist with the installation/start-up of the system.
- Electrical / Water / Air / Drains ready prior to arrival (Floor drain in vicinity of tank)

Note *If the AquaVision controller is part of the purchase, it is the customer's responsibility to set-up all network connections.*

The Jet Edge service engineer will demonstrate that the controller works on a network by communicating with the service engineer's laptop computer.

Note *If SigmaNest software is purchased, the customer is responsible for loading the software on their computer prior to the training session.*

Required Equipment

The following items must be available for the installation.

- Leveling Transit (non laser type)
- 1/2 gallon Acetone
- Clean coffee can
- Hammer drill with 1/2" cement bit, 12" long
- Sixteen weights for Chockfast forms (i.e. 2-3 lbs steel scraps)
- Wet/Dry vacuum
- 1/2 inch hand drill (Heavy duty 3/8 inch drill will work)
- Step stool or small ladder (3 foot)
- Six foot ground rod installed near control box location (or equivalent ground)
- #10 gage ground wire and clamp to ground the high rail controller
- Air pressure with hose and nozzle
- Forklift (3,000 lb. minimum, 5,000 lb. recommended)
- Pallet Jacks
- Access to a bench vice
- Network communication Link

Required Service Tools

- 0-300 ft/lb Torque Wrench 3/4" Drive
- 3 or 4 inch Extension for Torque Wrench
- 0-75 in/lb Torque Wrench
- Deep Socket for the torque wrench

Pump Model	Socket Size
All 36K Units	1-1/2 inch
55-30 – 55-75A	1-5/16 inch
55-75B – 55-150	1-1/2 inch

- 3/32–3/8 inch Hex Key sockets for Torque Wrench
- Ball End Hex Keys (Allen Wrenches) Metric & Standard
- Combination Screwdriver Set
- Adjustable Wrenches (6 inch, 12 inch, 15 inch, and 18 inch)
- Open-Box End Wrench Set (5/16–1 inch)
- Pliers Set
- Volt/Ohm Meter
- Spud Wrench 0–2 1/2 inch capacity
(similar to a pipe wrench but with smooth jaws)
- Rubber Mallet
- Heavy Duty Bench Vise
- Pick Set
- Transfer Pump with 10 micron filter for transferring hydraulic fluid

Hydraulic Fluid Selection Chart

The intensifier pump uses hydraulic fluid to power the intensifier.

- Intensifier pumps shipped by ground have hydraulic fluid in the hydraulic fluid tank.
- Intensifier pumps shipped by air do not have hydraulic fluid in the hydraulic fluid tank.

Company	Brand Name	Grade/ Callout	Viscosity	SUS	ISO-VG Grade/ID	Viscosity Index
American Oil Co.	Amovis AW	46	200-220	47.0	46	92
	Rykon	46	212	49.3	46	125
Atlantic Richfield	Duro AW	S-125	205	47	46	95
Ashland/Valvoline Oil		AW 20	195/225	47	46	95
BP Oil, Inc.	Energol HLP	46	221	47	46	95
Bel-Ray Co., Inc.		LT-200	200	51.3	46	163
Chevron Oil, Inc.	Chevron EP	46	215	48	46	95
Cities Service Co.	Citgo A/W	46	215/225	47.6	46	95
	Pacemaker XD				46	
Conoco	Super Hyd oil	21	215	48	46	100
Davis Howland Oil	DSL - 40	45	210	47	46	100
Dryden Oil Co., Inc	Drydene Blue	10	215	48	46	104
Dryden (CTD)	Paradene AW	46AW	215	48	46	102
Exxon Co.	Nuto H	46	220	48	46	102
Fiske Bros. Refining	Lubriplate	H01	213	49	46	120
Gulf Oil Co.		46AW	220	48.2	46	105
E.J. Houghton & Co.	Hydrodrive hp	200	190/210	47	46	95
Kendall (CTD)	Kenoil R&O	047-EP	200	47.2	46	110
Lubrication Engineers	Monolec	6110A	210	47	46	95
A. Margolis & Sons	Silogram M.P.	207	205	47	46	105
	Silogram TIP100	20-7	205	47	46	109
Mobil Oil Corp.	Mobil DTE 10	15	205	52	46	150
	Mobil DTE 20	25	215/240	47	46	95
Penzoil*	AW HYD Oil	46	230	47	46	
Phillips Petroleum Co.	Magnus A	215	225	48	46	110

Company	Brand Name	Grade/ Callout	Viscosity	SUS	ISO-VG Grade/ID	Viscosity Index
Standard Oil of Ohio	Industron	48	221	47	46	95
Sun Oil Co.	Sunvis 700	747	208	47.4	46	104
	Sunvis WR	821wr(46)	236	48.6	46	98
	Sunvis Hyd oil	2105	194	52	46	176
Texaco, Inc.	Rando	HD46	215	47.7	46	102
	Regal R&O	AW46	237	48	46	102
Union Oil Co.	UNAX AW	215	215	48.1	46	107
	Spec Hyd oil	215	215	47	46	95
A.C. Withrow Co.	H Series	medium	236	49	46	

* The hydraulic fluid supplied in pumps that are shipped by ground.

Training

Training is provided while the Jet Edge service engineer is on site during the motion control system installation. Additional training can be scheduled.

On site training

Jet Edge will provide up to four hours of on-site operator training on the motion control system. This will familiarize the operator(s) which should have a CNC background with the motion control system controller. If programming software has been provided by Jet Edge, the service engineer will provide up to four hours training to familiarize the programmer with the basic operation of the software.

Jet Edge will provide up to six hours of on-site maintenance training to familiarize the operator(s) and maintenance personnel with the overall waterjet system functions and maintenance.

Note *Any additional time needed for installation and training will be billed at the standard rate.*

Off site training

Jet Edge offers additional training classes in Minneapolis, MN throughout the year. There is a nominal charge for these classes. Additional classes can also be arranged at the customer's site. These classes are billed at the standard training rate in addition to any travel and living expenses incurred by the service engineer. For information on available training classes and costs please contact the Jet Edge service coordinator.